

# IMPORTANT

MICRO

*Design*

2

READ THESE NOTES  
BEFORE  
USING MICRODESIGN2

Copying & Installation Notes v1.6

# COPYING & INSTALLATION NOTES

## Working Copies and Disc Security

Although the **MicroDesign2** Program disc in this package is fully functional, we strongly recommend that you do NOT run the program from this master disc, except to work through the introductory Tutorial described in the User Manual. As with any master disc, you should make working copies, and store the original in a safe place.

The **MicroDesign2** Program disc is copy-protected, however, and you will not be able to use normal disc-copying programs such as Disckit to make your working discs (or to Verify the master Program disc). Instead, a separate program called **MDMAKE** is supplied on the master Program disc which should be used to generate your working copies. Using **MDMAKE**, you can generate working discs on any floppy disc, and these can be made into Start-of-Day discs if appropriate. **MDMAKE** also allows **MicroDesign2** to be installed on a Hard Drive.

The working discs which you make and use will also be copy-protected, and will NOT contain the copying program **MDMAKE**. They cannot be copied or verified using Disckit, and you will not be able to generate additional working discs from them - this can only be done using **MDMAKE** from your Master program disc. We do not intend that this security system should inconvenience our users, but it is necessary in order to prevent unauthorised copying of **MicroDesign2**. We allow you as a legitimate user to make copies for your own security and convenience: please do not abuse this act of trust by making illegal copies to sell or give away to your friends. After all, if they BUY the program, everyone (including you) will receive better after-sales support. *Please note that any copies made from your program disc will bear your serial number, and can be traced back to you.*

Many thousands of man-hours went into the development of this program, and we cannot afford to give this work away. Software piracy is THEFT!

## The Introductory Tutorial

Also supplied on the master Program disc are various files for use when working through the Tutorial described in the User Manual. Since you will not normally require these files when using **MicroDesign2**, they are not copied onto your working discs. You should run the program from your master to work through the tutorial - this is the only time that you should use your master Program disc to run **MicroDesign2**.

## Copying the Library Files

Whether supplied as 3" or as 3½" discs, the Library material (Fonts, Icons & Areas, and Cuts) supplied with **MicroDesign2** is not copy-protected in any way. The files may be copied individually, or the disc(s) copied as a whole, using Locoscript, Disckit, PIP, NSWP or any other copying utility.

3" versions of the Library material are supplied as CF2 **Single-Density** discs. Owners of PCW9512 computers should use the program 8000COPY (which is supplied on your CP/M system disc) to copy the 3" Library material onto a disc formatted on your **Double-Density** drive(s).

# COPYING & INSTALLATION NOTES

## Using CP/M

**MicroDesign2** and the other programs described here all run under CP/M Plus. For those unfamiliar with this operating system, your PCW is supplied with a disc labelled CP/M PLUS. Use this as a Start-of-Day disc: turn the power on, insert the disc with its CP/M side towards the screen, and an **A>** prompt will shortly appear on screen. You are now 'in CP/M', and can run programs from here. Consult the PCW User Guide for further details.

## Making a Working Disc using MDMAKE

To make a working disc, or to install the program on a hard disc, first format a floppy disc using Locoscript or the Diskit program supplied on your CP/M system disc. Then, at the CP/M **A>** prompt, insert the **MicroDesign2** master Program disc in drive A: (C: for Cirtech hard drive users) and type:

```
MDMAKE [RETURN]
```

The necessary files will be read from the master disc, and on-screen instructions will then be given, allowing you to select the drive on which your working copy will be made.

When your working copy is completed, your master should be stored away, and the program can be run by inserting the copy and typing:

```
MD [RETURN]
```

## Making a Start-of-Day MicroDesign2 Disc

A Start-of-Day disc is one that allows you to turn on the PCW, insert the disc and wait while the machine loads CP/M and runs your chosen program.

To make such a disc, you **MUST** generate your working copy in floppy drive A: - when the working copy has been made, you will then be offered the option of making it into a Start-of-Day disc. Have your CP/M system disc ready, and follow the on-screen instructions.

The Start-of-Day disc thus created can be placed in the A: drive of your PCW after having switched on the power, and **MicroDesign2** will be run automatically.

## Installing MicroDesign2 on a Hard Drive

**MDMAKE** offers the opportunity to copy **MicroDesign2** onto any User group of any Hard Drive. You will still, however, need a normal floppy working disc in any floppy drive to act as a security 'key-disc' when the program is run from the Hard Drive by typing:

```
MD [RETURN]
```

# COPYING & INSTALLATION NOTES

## Drive M:

**MicroDesign2** and **MDMAKE** both use all the PCWs available memory, and so any files stored in the M: drive will be lost when these programs are run.

## Your Master Discs

The master discs supplied in this package should be treated carefully. Once working discs and other copies have been made, these original masters should be stored away from magnetic fields, sunlight, damp, etc.

*Please note that your master discs are supplied write-protected - Creative Technology cannot be held responsible for any loss of data or damage caused if the write-protect is removed.*

## Technical Support

We would like you to get the best from **MicroDesign2**. Should you experience difficulties with the operation of this software, please contact us either by post at the address given in the User Manual, or by telephone on 0889 567160. For general operational assistance and technical advice, we would *prefer* to receive phone calls between 4pm and 7pm Mon-Fri, and in most cases it is much more useful if you can call us when you are sitting at your PCW with **MicroDesign2** running.

Please do NOT ring to tell us that you are unable to copy or verify your Program disc using Diskit - read these notes instead!

**Good Luck and Happy MicroDesigning**

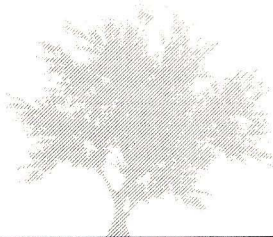

**CREATIVE TECHNOLOGY (MicroDesign) LTD.**

MICRO

*Design*

2

for the AMSTRAD PCW series

SUPPLIED LIBRARY  
(CUTS & AREAS)

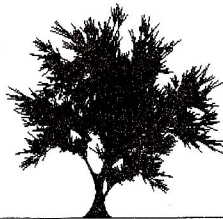

CREATIVE TECHNOLOGY

# CATALOGUE - SUPPLIED LIBRARY

## Supplied .MDAs

The following .MDA files are supplied as part of the MicroDesign2 PCW library, and may be found on the disc marked ICONS & AREAS.

SCALE.MDA

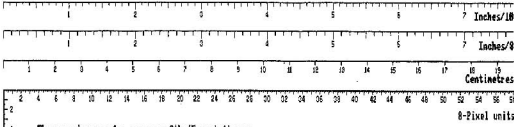

DISCLABL.MDA

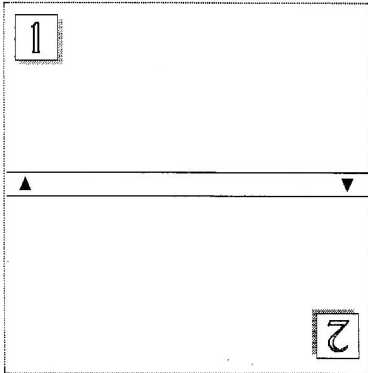

HICROSS.MDA

CASSLABL.MDA

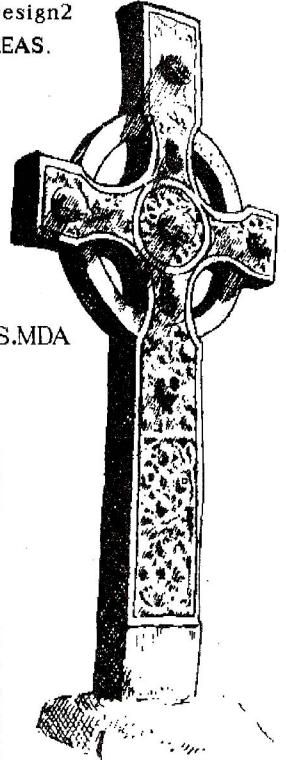
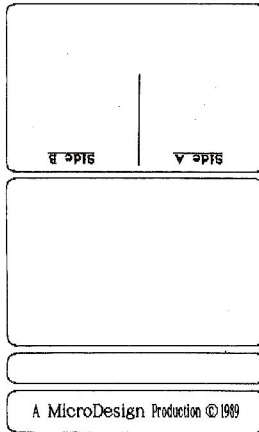

CHURWNO.MDA

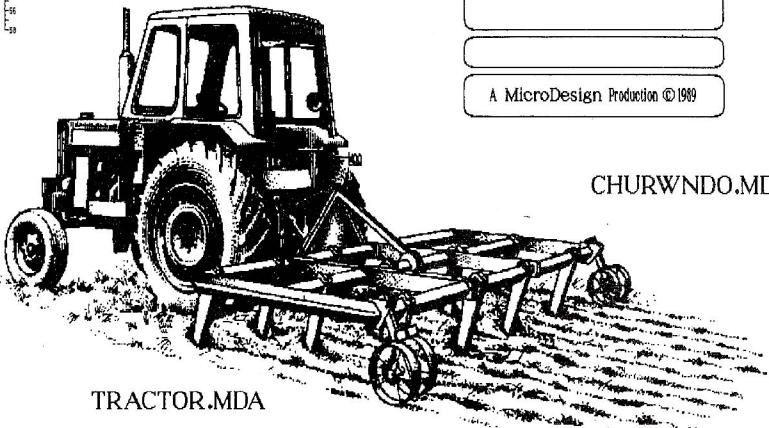
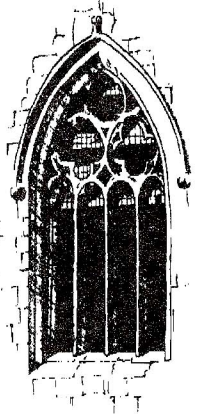

TRACTOR.MDA

# CATALOGUE - SUPPLIED LIBRARY

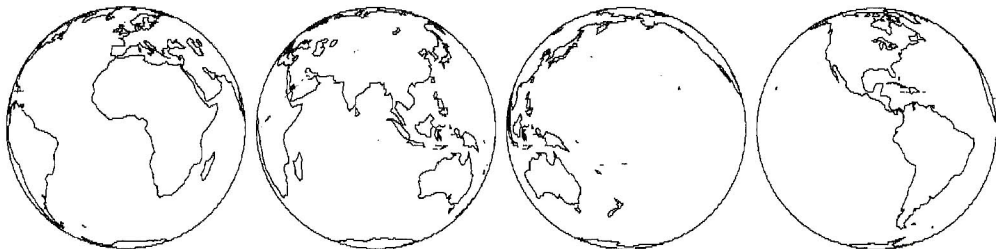

GLOBES.MDA

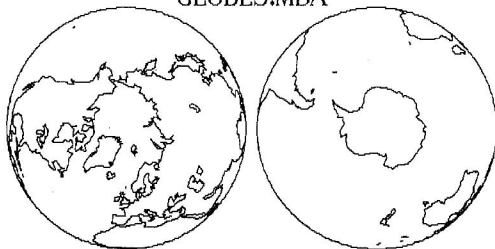

BRITAIN.MDA



WORLDMAP.MDA

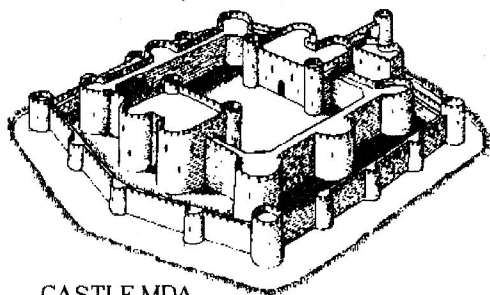

CASTLE.MDA

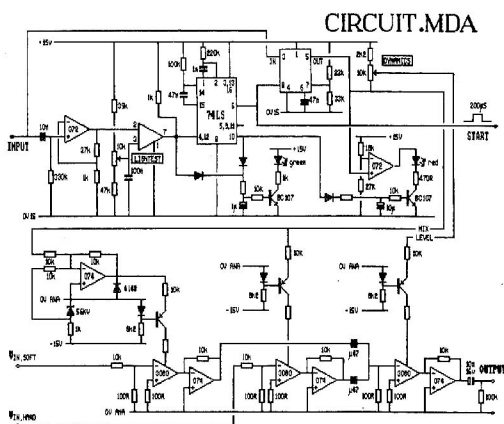

# CATALOGUE - SUPPLIED LIBRARY

## Supplied CUTs

The following .CUT files are supplied as part of the MicroDesign2 PCW library, and may be found on the disc marked CUTS.



MDLOGO.CUT

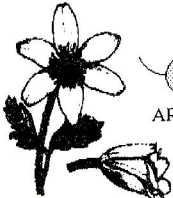

ANEMONE.CUT



ARTMOUSE.CUT



ACCESS.CUT

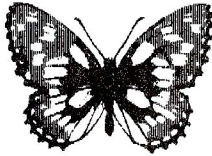

BUTTRFLY.CUT



DUCK.CUT

CASTLE.CUT

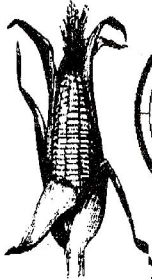
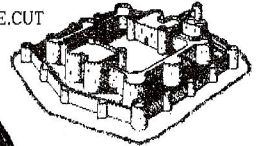

CORNCOB.CUT

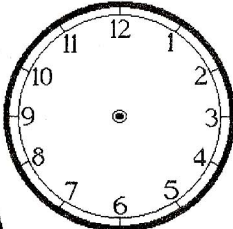

CLOCKFACE.CUT



CORNKNOT.CUT



SAVEIT.CUT

WHEAT.CUT



CLUBS.CUT



ENDKNOT2.CUT



ENDKNOT3.CUT



DIAMONDS



SQUIRREL.CUT



FNTMOUSE.CUT

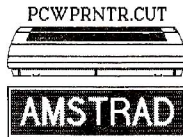

PCWPRNTR.CUT



ENDKNOT4.CUT



HEARTS



ASHLEY.CUT



SPADES



GENTS



LADIES



FRANCE.CUT



CHEMICAL.CUT



GEESE.CUT

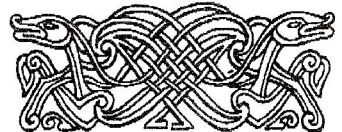

ENDKNOT1.CUT



ARCHERY.CUT



SWIMMIMG.CUT



VOLLBALL.CUT



FINGER.CUT

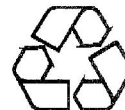

RECYCLED PAPER  
RECYCSYM.CUT



POISON.CUT



# THE MICRO Designer

ISSUE 5

Published in Uttoxeter

March 1991

By subscription

Creative Technology (MicroDesign) Ltd.

**S**pringing into life after a long and freezing winter, your favourite quarterly is back (and only a month late!). In this issue, Hogweed and his Helpful Hints are taking a short holiday, to make room for us to print a few of the many superb entries we received for the Herbert Award competition which was announced in the last issue. We also have our regular News and Dear Hamish columns (not to mention lots of lovely advertising), but first, the preamble...

The MicroDesigner does cause some confusion, and not just because it belongs to that strange group of items whose existence can only be defined in terms of their perpetual lateness (other items in this group include homework, trains, and telephone bill payments). It seems that some people do not know where MicroDesigners come from, so for the benefit of those who go searching vainly under their gooseberry bushes every three months, here is a brief explanation...

We do not charge for the newsletter, but we do ask you to supply a stamped addressed envelope so that we don't have to pay for the postage, and we also ask

you for an extra first-class stamp (currently 22p) for each issue you order: this helps to cover the printing costs. So if you want to receive the next issue, just send an SAE and an extra stamp: we put the envelopes in a big box, and when copies of the new issue arrive, we put them in the envelopes and post them. If you want back issues, send only one SAE, but an extra first-class stamp for each issue you want. It helps us if you write on the envelope which issue(s) you want us to put in it. Please note also that because of our high-tech 'big box' system, we have no idea who has sent envelopes and who hasn't.

So that's how to get the MicroDesigner: now read on to see if it's worth getting...

Each page of this issue (unless marked otherwise) was designed and printed using MicroDesign2, ProSCAN, and a HP Deskjet printer.



## PRINTERS

### OKIMATE

We've some good news to pass on to owners and potential purchasers of Okimate 192 Microline printers: a new ROM is now available to make your printer MicroDesign-compatible. The P107 ROM is available from Oki Data in Slough ... contact them for price and details.

### DESKJET...

The good news is that two different companies will shortly be offering a re-inking service for the HP Deskjet printer. The even better news is that the refills will be available in a selection of colours, including blue, red, green, violet and brown, as well as a new indelible black ink.

Rodesign will be selling re-inking kits for empty cartridges: two refills will cost £14.95, in any colour.

And Robin Hosford of DDTF informs us that he will be offering a re-inking service: just send him your old cartridges for refilling in any of the new colours, or the normal black.

See the advertising section for more details of both offers.

## THE SPRINTER

We can confirm that Cirtech's magic box for the PCW, the Sprinter, is compatible, and very useful, with both MicroDesign2 and ProSCAN. The Sprinter speeds up the PCW's processing, and this does create some interesting effects with some key functions in both programs: using the cursor keys in the Font and Icon grids, for example, takes a little getting used to, but the general operation of the programs is not affected significantly.

### ...AND BUBBLEJET

Canon have just released a new addition to their Bubblejet range of inkjet printers. The BJ300 is a high-quality A4 printer with excellent paper-handling, and we can recommend it very highly: HOWEVER, anyone wishing to use it with MicroDesign2 or ProSCAN should note that it will only print if its emulation is set to Epson mode, and because it is compatible with the Epson 24-pin standard, the Printer Type option should be set to 24 pin A, not CANONBJ!

## USER GROUPS

### OOP NORTH...

As some of you may have seen in 800PLUS, Phil Cole from Rotherham has set up a 'MD2 International User Group'. This group offers a technical support and ideas-swapping network for all MicroDesign2 and ProSCAN users: for more details, write to Phil at 15 Elsham Close, Bramley, Rotherham, S66 0XZ enclosing a stamped, addressed envelope.

### ...AND DOWN UNDER

David York, the secretary of the Amstrad PCW Australia Group, has written with details of the organisation...

'We are a group composed entirely of PCW owners. We are Sydney-based, meeting every second Tuesday of the month at Burwood RSL Club, NSW, at 7.30pm.

Our meetings don't usually attract a big attendance, though many of the regulars travel quite a distance to attend. Our membership is spread throughout Australia, mostly NSW, Queensland, Victoria, Western Australia, and Tasmania. We keep in touch through the pages of our monthly newsletter (produced since November 1989 with MD2, of course).

Anyone interested in contacting us can do so by writing to  
The Secretary, P O Box 478,  
Smithfield, NSW 2164, Australia.





## PROSCAN

One of the limitations of the ProSCAN system is that it can only scan an image which is up to 4 inches wide. To get around this problem, we have now added a new feature: the ProSCAN software and interface can now be used in conjunction with an Amstrad Fax machine to scan full A4 pages. The Fax machine comes in several different models, but there are two types which have a scanning facility: the FX9600T and the FX9600AT. These can be connected (using a special cable) to the ProSCAN interface, and controlled using the ProSCAN software.

The ProSCAN Image-Source Option must be changed if you want to use a Fax scanner: the FX1 and FX2 settings refer to two different types of Fax machine. Just to add to the confusion, both FX9600T and FX9600AT machines are sold in FX1 and FX2 versions: units made in the UK or Ireland are normally FX2, while those made in the Far East are FX1. If you are not sure which setting to use, just try both: you can't do any damage. The Fax scans

at 200 dpi, and has its own grey-scale and brightness controls.

If you want to buy ProSCAN for use with the Amstrad Fax, you do not need a scanning head with the package. The price for ProSCAN without scanning head is £119.95, and the special cable costs an extra £10.

## HEADLESS?

Buying ProSCAN without a scanning head may also be a good idea if you already have a hand-held scanner for another computer (a PC, for example). Most scanning heads will work with the ProSCAN software and interface, but *please* check your particular model with us before ordering.

## SNEAK PREVIEW



There are several mouse packages already available for the PCW, but if you are thinking of buying one, give us a call first: we may have some interesting news for you!

## COCKUP CORNER

Following last issue's announcement that MicroDesign2 now supports the wonderful new Canon Bjl0e printer, our PCW programmer has an embarrassing confession - a major bug slipped through in the very few v1.22 copies of MD2 which were released to Bjl0e owners. If you have one of these v1.22s you will probably find that using the Triangle operation is a very bad idea, and that returning the master Program disc to us for replacement with version v1.23 is a very good one! This only affects about a dozen users who may have received these v1.22 upgrades - and the programmer, who has been forced to eat ten thousand (triangular) Tortilla chips by way of atonement.

It has also been brought to our attention that a *very* strange gremlin got in the works when the master copy of Extra Fonts Disc No 3 was being prepared. If you examine our latest magazine advert carefully, you will see that the capital A in Seraphi5 (the main body-text font used in the advert) somehow got reflected: this produces a rather odd-looking result, with the weight on the leading edge of the character. We would recommend that any perfectionists among you who have bought XPD3 correct the error using the Fonts section of MicroDesign2. Load Seraphi5, then Edit the capital A. Use X to Reflect the letter, then N to Nudge it back to the left hand side of the grid, then K to Keep the result back in the capital A position, and f4 to resave the font.





## LIBRARY NEWS - FONTS

**Y**es, you guessed it: there's another Extra Fonts disc out! We have just finished XFD4, which is a little different to our previous efforts, with greater emphasis on a wide range of body-text fonts in the 10-16pt range. Cuckoo is included at 12 and 14 point, and there are also several sizes of five new fonts: Slenda, Scotch, Trad, Type and Eric. We are also including complete Italic, Bold and even Wide versions of a few fonts: these give better results than the standard fonts typeset with italic or bold options. Some examples are shown here: like the rest of our Font library, this disc costs £14.95.

**XFD4 INCLUDES:**

**THREE NEW** sizes of Cuckoo

*Four variations* of this design, which is called **ERIC**

**Eight versions** of *this font*, called **Scotch**

An elegant new type-face called **SLEND**A

Several different sizes of **Trad**, including an **INLINE** version

And finally, **three new** FONTS CALLED **SQUARE**, **TYPE** and **WIDE**.

**ROCK ON!**

A new name on the library scene is **Crazy Diamond**. Their new package, "Harmony", is a disc of graphics and fonts designed to help you produce musical

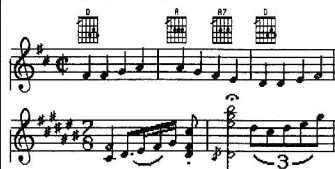

manuscript. With the musical 'lines' stored as MDAs, and the notes, clefs and other symbols supplied as fonts which can be 'written' straight onto the lines, the system is surprisingly easy to get used to, and very well documented. There are even fonts of guitar chords, and icon sets which include rests, repeats, and other musical twiddly bits, all for £16.99. See the advertising section for more details.

**COMING SOON...**

In response to requests from our trade customers, we have now put together a new Fonts release which will appear in the shops. The 'MicroDesign2 Font Library' is a package comprising our own Extra Fonts discs 2 and 3, and costs £29.95.

**A NEW SLANT**

**Exemplar Design** are about to release an interesting new set of typefaces called 'MicroDiagonals'. These are letters supplied as individual CUT files, which have been rotated to give diagonal lettering: see Exemplar's advertisement for more details.





## GRAPHICS

**Mick Harrison** has extended his enormous range of graphics discs even further. Since the last MicroDesigner, Mick has added seven discs to his library, bringing the total to an amazing 16 different discs, ten of them in double-density format. He is still concentrating on animals and wildlife, but several other subjects are covered: see his advertisement for more information.

**AGB Illustrations** have also produced a new disc, called **Borders**. This is unique in that it includes icon sets as well as lots of different border designs. The borders cover a good range of subjects, (including vegetables, a tape measure, and Henry the Eighth!) while the icon sets contain gardening and astrology symbols: see **AGB's** advertisement for more details.

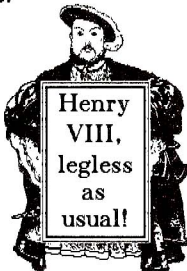

**RODESIGN** is now producing graphics library discs. Three discs are currently on offer: Christmas and Musical clip-art, and a disc of tools which includes high-quality diagrammatic pictures of woodworking, gardening and decorating implements. Prices and other details are in Rodesign's advertisement.

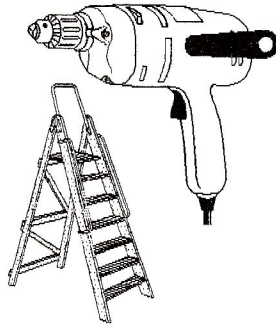

Finally, **HD Design** have a number of new discs available, in both PCW and PC format. Their **Fineline** library, which was mentioned in the last issue, has been expanded to four standard or two double-density PCW discs (so that it is now compatible with the 8256), and there are also more discs of pictures available from HD's resident artist **P B O'Rourke**. See HD's advertisement for more information.

## MD2-PC

As we mentioned in the last MicroDesigner, there is now a new version of MicroDesign2 for PCs and compatibles. It feels very similar to the PCW version, but it also includes the high-quality printer drivers and some other new features from the ProSCAN software. It also uses the same Area, Font, Icon and Text file formats as the PCW version, and if you wish, you can transfer your PCW files onto MSDOS discs via Locomotive's "Locolink", or any similar file transfer system.

To use MD2-PC, the minimum hardware you will need is MSDOS 3.2 or 3.3, CGA graphics, and 640K of RAM. One important point is that anyone buying a PC to use with MD2 should avoid MSDOS 4, and the 'Hercules' video system: EGA and VGA systems work fine. MD2-PC costs £69.95, or £49.95 for registered PCW MicroDesign2 users, and all our Extra Fonts and graphics discs are available in PC format. The program includes a 'Manager', which can convert clip-art files between different PC file formats.



# Dear Hamish ...



Need help? Just write to Hamish, CT's very own Agony Uncle and part-time draught-excluder, for witty, concise and sometimes even useful answers to your MicroDesigning questions.

**Dear Hamish ...**

**I have had enormous difficulties with the reverse feeds on my Star LC10 Colour printer. I followed the instructions for calculating the reverse feeds in the print Queue, but it never seems to come out quite the same each time, and as soon as I switch from single-sheet to tractor-fed paper, the result looks like something from an Acid House video. Should I adjust my vertical hold?**

J Ceasar, Italy

*Hamish says ...*

Your vertical hold is your own business, but there is a way round the problem. Instead of using method described by Hogweed in issue 1, you can actually tell the printer where the top of the page is (codes 27,52), and then tell it to return to the top after printing each Area (codes 27,12). A typical print queue for the LC10 might look like this:

```
*codes 27,52      Set 'top of page' here
*firstmda.mda
*codes 27,12      Wind back to 'top of page'
*secndmda.mda
*codes 27,12      Wind back to 'top of page'
```

...and so on. Don't forget to include the colour change codes if you want them, and remember the trick of winding forward a little after winding back to take up the slack.

**Dear Hamish:**

**Why does the 'COPIES' option in the Print menu totally fail to have any effect when I'm printing on my Deskjet using the Laser A option?**

R Murdoch, Docklands

*Hamish Says...*

Because you should be printing on paper. However, if you insist on printing on your Deskjet, use the Print Queue to print the same page several times. First load your page, then set up a queue with the line '\*CURRENT' repeated for each copy you want to print. Finally, start Printing the Queue, and don't forget to switch the Form Feed option on.

**Dear Hamish:**

Sometimes when I FIX a Shape operation using the Patterned Fill, the fill pattern looks completely wrong. If I UNDO and then immediately FIX again, the pattern is fine: should I wash my feet more often?

L Da Vinci, Florence

*Hamish Says...*

Almost certainly, but that is not the cause of this particular anomaly: it is actually (dramatic chords) a bug in the program. The programmer has, of course, been shot at dawn (or at least as soon as we could get him out of bed), but for the moment, you'll just have to keep UNDOing and re-FIXing.

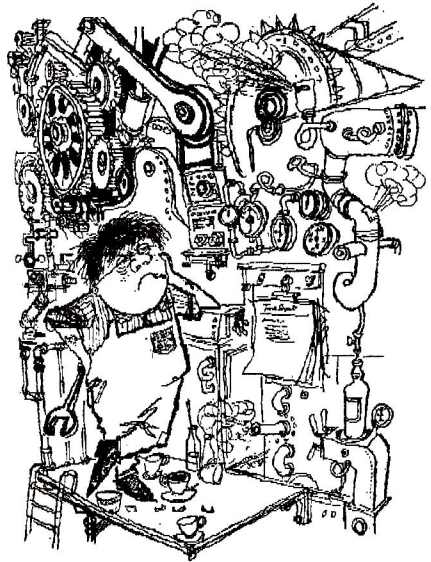

Some people will try anything to speed up the PCW's dot-matrix printer (*see below*)

**Dear Hamish:**

I would like to know whether there is any material advantage in printing in the "Quality" mode instead of "Draft". The only difference seems to be that printing in Draft takes a long time, and printing in Quality takes a ridiculously long time...

D Dickinson, Oswestry

*Hamish Says...*

There is no difference in the dot-information sent to the printer in the two printing modes, so if your printer mechanism works properly, there should be no problem printing in Draft all the time.

Draft printing requires the printer to move the paper different distances between each printed 'stripe' (made up of several lines of dots), and some printers with rather worn mechanisms produce uneven results because of this: Quality mode prints only one line at a time, moving the paper the same distance after each line, and thus producing a more even result on an ageing printer. As to the Draft printing time, it is simply the best we can manage: you can see from the previous letter that we now have a vacancy for a programmer, so perhaps you'd like to come and have a go yourself...



# THE HERBERT AWARD



In issue 4, we announced that we would be awarding a prize, **The Herbert Award**, for the best piece of MicroDesign2 or ProSCAN work sent in by you, the users. The competition has generated such a tremendous response that we have devoted four pages in this issue to the best entries. Deciding on a winner was virtually impossible, not just because the quality of work was so high, but also because there were so many different approaches to using the programs: how, for example, should we judge a 20-page newsletter against a single but quite beautiful scanned picture or photograph, or a

PCW printout against a page from a Deskjet? As you can see from the examples we have printed, the range is very wide indeed.

We finally decided to issue "Highly Commended" certificates for the best few entries in each of three categories: Artwork, Publications, and Page Design. We have also selected one overall winner. The examples shown are all photo-reduced from actual printouts, and the text on these pages was printed using ProSCAN on a Canon BJ300 printer.

## PAGE DESIGN

The Page Design category is for single pages which combine text and graphics with a particular flair for design: many of the best entries were from teachers and lecturers. Certificates go to **Khalid Rashid** for his Donna Summer News-sheet, and to **John Skillcorn** for a large number and variety of classroom work-sheets, posters and forms, all designed for Sandhill View School in Tyne and Wear.

**DONNA SUMMER NEWS**  
WINTER 1985 ISSUE No.2

### ANOTHER PLACE AND TIME

WATCH OUT BILL COSBY! HERE COMES THE SUMMER SHOW!

WINTER 1985

## DESTRUCTION!

SEVERE WINDS DESTROYED...

FOR BOSS SEC...

7:30 ON BUBBLES AND BOW CARBON!

ISSUE No.2

WINTER PLACE AND TIME

National Curriculum: Science Attainment

Name: \_\_\_\_\_

	1	2	3	4	5	6	7	8	9	10	Year	Class	Teacher
1	(A)	(A)	(A)	(A)	(A)	(A)	(A)	(A)	(A)	(A)	R	4B	
2	(A)	(A)	(A)	(A)	(A)	(A)	(A)	(A)	(A)	(A)	R	4B	
3	(A)	(A)	(A)	(A)	(A)	(A)	(A)	(A)	(A)	(A)	R	4B	
4	(A)	(A)	(A)	(A)	(A)	(A)	(A)	(A)	(A)	(A)	R	4B	
5	(A)	(A)	(A)	(A)	(A)	(A)	(A)	(A)	(A)	(A)	R	4B	
6	(A)	(A)	(A)	(A)	(A)	(A)	(A)	(A)	(A)	(A)	R	4B	
7	(A)	(A)	(A)	(A)	(A)	(A)	(A)	(A)	(A)	(A)	R	4B	
8	(A)	(A)	(A)	(A)	(A)	(A)	(A)	(A)	(A)	(A)	R	4B	
9	(A)	(A)	(A)	(A)	(A)	(A)	(A)	(A)	(A)	(A)	R	4B	
10	(A)	(A)	(A)	(A)	(A)	(A)	(A)	(A)	(A)	(A)	R	4B	
11	(A)	(A)	(A)	(A)	(A)	(A)	(A)	(A)	(A)	(A)	R	4B	
12	(A)	(A)	(A)	(A)	(A)	(A)	(A)	(A)	(A)	(A)	R	4B	
13	(A)	(A)	(A)	(A)	(A)	(A)	(A)	(A)	(A)	(A)	R	4B	
14	(A)	(A)	(A)	(A)	(A)	(A)	(A)	(A)	(A)	(A)	R	4B	
15	(A)	(A)	(A)	(A)	(A)	(A)	(A)	(A)	(A)	(A)	R	4B	
16	(A)	(A)	(A)	(A)	(A)	(A)	(A)	(A)	(A)	(A)	R	4B	
17	(A)	(A)	(A)	(A)	(A)	(A)	(A)	(A)	(A)	(A)	R	4B	

© Statement of Attainment. (A) Work covered. (R) Assessment passed.

**Khalid Rashid**

How high the gull fly  
How low the...  
How and the farm led  
Deep in play  
Felt like a grain on your sand  
How well the sheep's bell  
Waste make  
Ringing the giff  
When fancy takes  
Felt like a tide left me here  
How bliss the forest  
I wish bird song  
How neat the oat past  
Laid so long  
Felt like a seed on your land

**John Skillcorn**

### The National Curriculum - SCIENCE

You already have thought about, and written about, some animals which are able to fly. This leaflet aims to answer the old 'old' of 'why'. Look at the pictures on this page. They show a **BIRD**, a **MAMMAL**, and a **REPTILE**.

**WHAT YOU HAVE TO DO:**

Class one of the animals and answer the following questions:  
What is the name of the animal you have chosen?  
How does it fly?  
How does it breathe?  
How does it see?  
How does it hear?  
How does it smell?  
How does it taste?  
How does it feel?  
How does it think?  
How does it move?  
How does it grow?  
How does it reproduce?  
How does it die?

Special feature No. 1  
Special feature No. 2

Name: \_\_\_\_\_  
Registration Class: \_\_\_\_\_  
Date: \_\_\_\_\_

**Language**

Language is a system of symbols which serves several purposes. The language of art, science, mathematics, music, drama, poetry, prose, fiction, and non-fiction are all different ways of using language to express ideas and feelings.

Language is a system of symbols which serves several purposes. The language of art, science, mathematics, music, drama, poetry, prose, fiction, and non-fiction are all different ways of using language to express ideas and feelings.



# THE HERBERT AWARD









# ARTWORK

This category was rather complicated by the fact that some people were scanning existing artwork with ProSCAN, while others used the graphics tools in MicroDesign2 and ProSCAN to create pictures directly on the screen. Special mentions go to:

**Derek Attwood**, partly for his lakeland landscapes, but mostly for the address label on his envelope; **Paul Robinson** of Marple for his horses; **Derek Chatterton** from Stevenage for his Mozart CD cover; and **Mr B Thompson** of Kirk Michael in the Isle of Man, for his sheet of stamps.

Certificates of MicroDesigning excellence for: **Rosemary and Alexander Hulse** for their picture of Hogweed and Herbert (yes, flattery will get you everywhere!); **David Axford** from Haslemere, for his Valentine's card (although he loses marks for terrible poetry, sorry Dave!); and **Norman Ashby**, who submitted two entries. One is an A4-size scan of a cat's face, taken from a photograph but perfected, we suspect, with a great deal of pixel editing; the other is a remarkable A2-size picture of Winchester Cathedral, made from four A4-prints. Particularly commendable is the fact that both these entries were printed on the PCW printer, which proves that everything comes to he who waits!

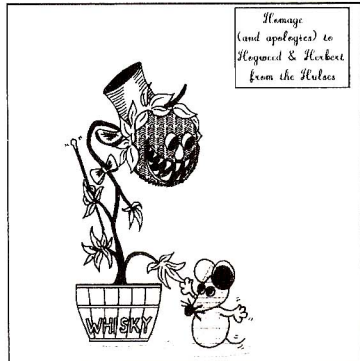

Rosemary and Alexander Hulse

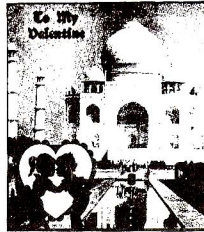

David Axford



Derek Chatterton



Derek Attwood

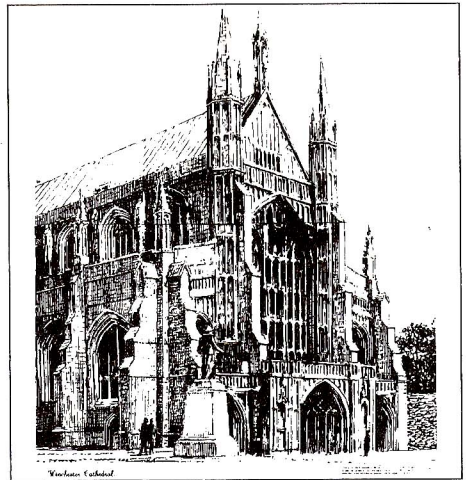

Norman Ashby





# And the winner is...

Dr Brian Davis of Aberystwyth University, for his remarkable diagrams of something bio-chemical: we don't understand any of it, but the design work is absolutely superb. Although Brian now has a 24-pin printer, the winning entries were sent to us some time ago and were printed on the ordinary PCW printer: no ProSCAN, no frills, just a lot of hard work. Our congratulations to Brian: the first Herbert Award is on its way to Aberystwyth.

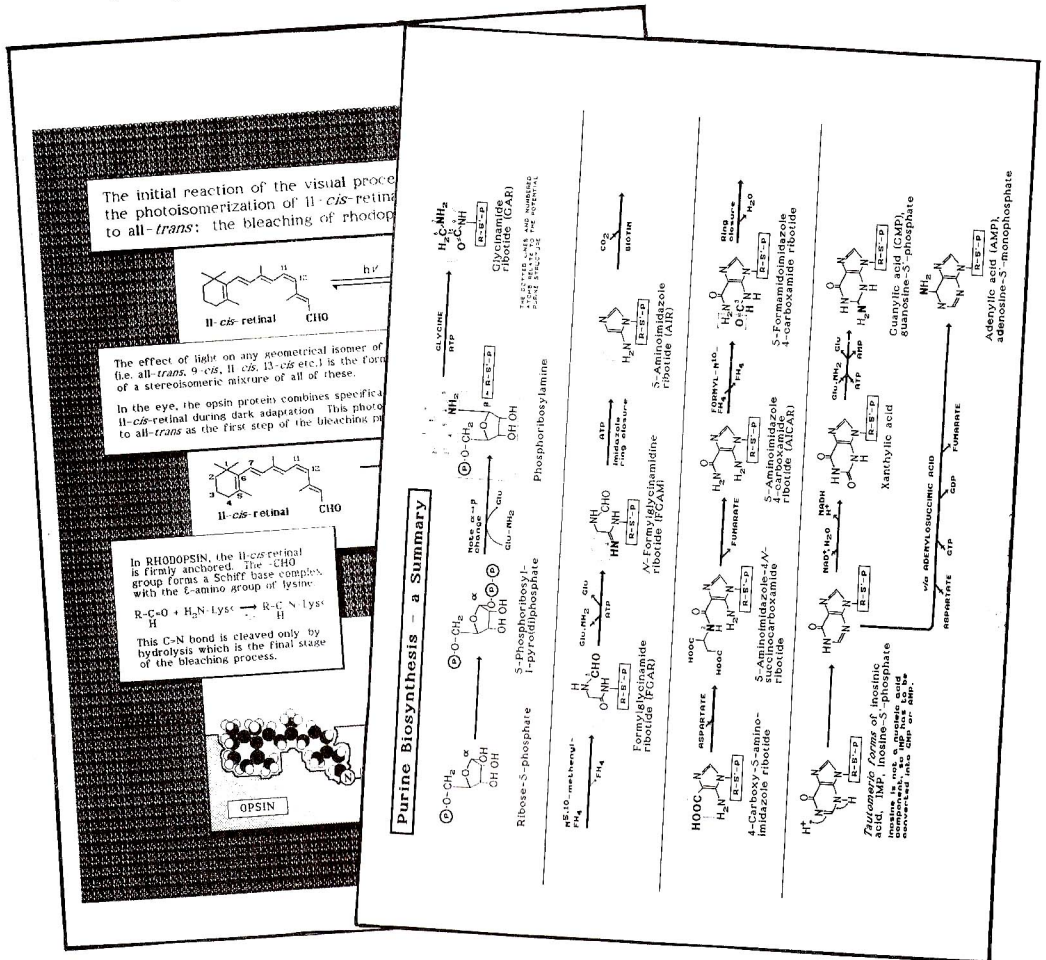

**MICK HARRISON'S DISC LIBRARY FOR MD2**  
16 DISCS IN TOTAL

Do You Need a Comprehensive Library of Ready Produced Graphics For Your MicroDesigning?

I Have a Total of 16 Discs with Hundreds of MDAs Ready for Loading into MD2 - Virtually Every Animal, Trees, Novelty Items, Signs of the Zodiac, Transport, Flowers, Sporting Activities, etc. etc.

Discs MWH1 to MWH6 are CF2 Format. Discs MWH7 to MWH16 are CF2DD for 8512/9512 users.

All Discs are Supplied with Catalogue Sheet.

Price £6.50 each incl VAT and P&P. TWO for £15.00 then £7.00 for each subsequent disc OR any 10 discs for £65.00 OR all 16 discs for £100.00.

**MICK HARRISON**  
263 ABBEY STREET  
DERBY DE3 3SW  
Phone 0332 381210

For PCW 8256 Users. Any Of The CF2DD Format Discs Can Be Supplied On Two KCF2 Format Discs For Use In Drive A At An Extra Cost Of £3.00 For Each CF2DD Disc.

PERSONAL SCANNING SERVICE AVAILABLE.

**Improve Your Image...**

HIGH QUALITY CLIP ART for MicroDesign2<sup>®</sup> (each disc is supplied with full print out of files)

**XMASCLIP**  
Single density disc containing 39 .CUT and MDA files. Make gift tags, place cards, Christmas cards etc. Includes decorative greetings messages, symbols and traditional scenes.

**MUSICAL CLIP**  
Single density disc containing 27 MDA files. Sketches and line drawings of musical instruments both traditional and modern. Ideal for Music Society newsletters, school projects or just for fun.

**TOOLBOX**  
Single density disc containing 65 .CUT and MDA files. All types of tools including carpentry, plumbing, electrical, decorating, gardening etc.

**GIANT FONT DISCS**  
Double density discs each containing 71 MDA files. Each is a complete font of 67 characters to create your own banners. Instructions for use with 'Print Queue' included.  
Disc1 - Times Disc2 - Guardian Disc3 - Daininger

ALL CLIP ART DISCS £10 each (inclusive)

**TRAINING...**  
Do you require tuition on MicroDesign2? Be trained in your own home or workplace by Rod Patient.  
Only £80 for full day (+travel)

All illustrations shown at reduced size

**RODESIGN**  
Dept C  
195 MILWARDS  
HARLOW  
ESSEX CM19 4SJ  
☎ 0279 444313

For more details give me a ring or send stamped SAE.

**AGB ILLUSTRATIONS**  
☎ 061-773-2702

**FOR MICRO DESIGN 2**

CA1 VARIETY DISC  
CA2 VARIETY DISC  
CA3 FLAGS OF THE WORLD  
CA4 THE SPORTS DISC  
CA5 MICRO DESIGN BORDERS\*

Picture reference supplied with all orders  
\*CA5 for Micro Design used on PCW 8512/9512 only

**ONLY £12-50**  
per disc incl P&P

**5 Queens Drive, Prestwich, Manchester, M25 8HQ.**

**DDTP & IDA**  
F.R.FDX TEL/FAX  
08045-3144  
Hot for Telephone

**Re-inking**  
Ordinary (Colours) £1:50  
(HT) £3:30 Gold/Silver £2:30  
\*NEW! PCW 16 Cassettes (Fabrica) £4:50

**Most Colours (Ordinary) £7:45**  
**Gold or Silver (Tel for Colour Availability) £9:95**

Heat Transfer Most Colours  
\*STAR 4 Colour Ribbons NEW as DIY Kits Ordinary £3:00  
Heat Transfer 4 Colour Ribbons - £7:00  
*Complete with Instructions*

**HP DeskJet Cartridges Re-Filled Black £10 - Colours £12! Yes Colour changes Possible!!!**  
**Tel for Colour Availability**

**NEW MICRODIAGONALS DIRECTIONS NEW**

Liven up your MicroDesign or ProScan layouts with eye-catching display text which runs diagonally up or down the page!

This classic typographical effect – never previously implemented on the PCW – greatly extends the scope for creative page design. If you're ready for a change of direction, you'll love

**★ MICRODIAGONALS ★**

– the utility which adds a new dimension to PCW publishing. It costs just £18.50 (including UK postage) for two CF2 discs containing over 400 files. Order with confidence from the desktop publishing specialists:

EXEMPLAR DESIGN  
P.O. BOX 683  
BATH BA1 1XU  
0225 315131

**NEW MICRODIAGONALS DIRECTIONS NEW**

# DIAKONOS

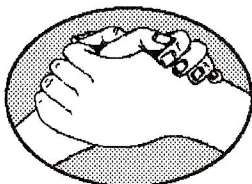

## SCANNING and DESIGN SERVICES

Scanning for MD2 @ £3 per image  
(Images more than 4" wide chargeable as two images)

Please quote printer type for photographic scans

Send formatted disc and SAE for return postage  
(CF2DD only - please do NOT send PCW8256/8512 A: disc)

1 Chapel Street Crewe CW2 7DO

# HARMONY



Musical notation within your Microdesign2 documents.

- No new program to learn - use your Microdesign2 knowledge.
- Comprehensive range of features to cover all aspects of musical notation, including guitar chords and Treble, Bass and Alto clefs.
- Easy and quick to use, with high quality output at two scales.

**— crazy diamond design —**

**£16.99**  
(INC. POSTAGE)

23 DAWES CLOSE,  
ARMITAGE, RUGELEY,  
STAFFS., WS15 4BE.



## inspiration

Services for MicroDesign Users

...now on PCW and PC computers!

### LASER PRINTING



High quality printed output  
All MicroDesign page formats supported  
Special paper or OHP available to order  
*30p per page (plus 99p per disc)*

### IMAGE SCANNING



Pictures, drawings, line art etc  
Converted to MicroDesign Area Files  
Retains original perspective  
*£3.99 per scan*

### FILE TRANSFER



Move files from PCW to PC and back  
All 3" PCW formats (single & double sided)  
5.25" & 3.50" PC formats (double density)  
*£4.99 per disc*

Add £1.25 carriage and VAT per order. Work normally processed within 24 hours and returned by first class post. Please write or call for an information pack.

Unit 7 . 7 Haydock Street . St Helens . Merseyside . WA10 1DD . 0744-55543

# Graphics Library

Two sets of graphics discs from the authors of MicroDesign2.

The PARISH Library is a two-disc set of clip-art suitable for use in Church publications for any denomination.

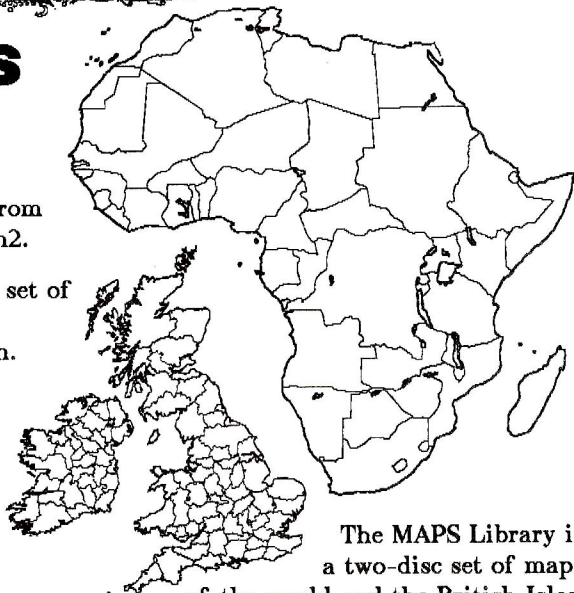

The MAPS Library is a two-disc set of maps of the world and the British Isles.

## CLIPART FOR PC AND PCW

### CLIPART FOR MICRODESIGN II PC

**FINELINE PLUS:** A COMPLETE SET OF 170 CLIPART GRAPHICS, IDEAL FOR BUSINESS EDUCATION, TUTORIALS, NEWSLETTERS & LEISURE. THIS COLLECTION CONTAINS BUILDINGS, OFFICE, COMPUTER, TRANSPORT AND MANY MORE USEFUL GRAPHICS. NO SCANNED IMAGES THESE ARE ALL CRISP LINE DRAWINGS DESIGNED TO COMPLIMENT YOUR DOCUMENTS. **PC VERSION £24.95**

**STOP PRESS!** *PCW VERSION NOW AVAILABLE £31.95*  
**ARTFILE ONE:** 140 GRAPHICS PENNED BY ILLUSTRATOR PB O'ROURKE. SUPPLIED IN MDA FORMAT FOR USE WITH PC'S £24.95

AVAILABLE FOR MD II PC ON 3.5" OR 5.25" PC DISKS  
 PLEASE WRITE OR PHONE FOR OUR FREE PC INFORMATION PACKS.

ALL HD DESIGN CLIPART IS PREPARED BY OUR OWN ARTISTS AND DESIGNERS SO YOU ARE ASSURED OF OUR COPYRIGHT LICENSE TO USE THEM.

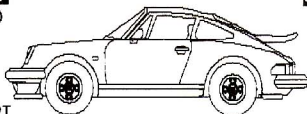

FINELINE PLUS

ARTFILE ONE OR PBO2



### CLIPART FOR MICRODESIGN II PCW

HD1 CLIPS & FONTS

HD2 DESKTOP MAGIC

HD3 IMAGE KIT

HD4 POSTER KIT

HD5 PAGE MAGIC

HD6 CARTOON FUN

HD7 PICTURE BOX

**CLIPART DISCS FOR THE PCW ARE SUPPLIED ON 3" CF2 DISCS £12.50 EACH**

### PB O'ROURKE CLIPART

A SELECTION OF FOUR DISCS OF ILLUSTRATIONS BY PROFESSIONAL ILLUSTRATOR PB O'ROURKE REF PB01, PB02, PB03, PB04 £12.50 EACH

*NEW!! FINELINE PLUS PCW: £31.95 BOXED SET FOR PCW 852/8512 & NOW 8258.*

WRITE OR PHONE FOR OUR FREE PCW CLIPART INFORMATION SHEETS.

**HD DESIGN** DEPT MDA  
 3 ROUNDTORN WAY, GOLDSWORTH PARK



WOKING, SURREY GU21 3QN

☎ (04867) 81394 ☎



Creative Technology Extra Fonts discs

For use with MicroDesign2 and ProSCAN

Extra Fonts Disc N01

Bagdad 32

Brush 26

Callig 25

Celtic 29

CURVER 24

Niblik 29

Outrig 30

Русиян 22

Schwab 25

Sherwd 27

Sossij 27

Tablet 26 40

Wobbly18

Times 22

**Bolden 42**

Brdway 40

**Grdian 44**

38 50 75

Extra Fonts Disc N02

Bagdad 25 48

**Bolden 17 22 33 84**

Celtic 58

ΕΛΦΕΤΙΚΑ 24 50

Helvetica 25 50

Medieval 26

Rondo 14 20 26

SHADOW 12

Helvoutic 25

Scribble 22 29

Tablet 20

**Grdian 88**

Extra Fonts Disc N03

Bagdad 17 22

**BALLOON 21 64**

Cuckoo 15 22 28

**Florid 16 20 29 40 60**

**Grdian 22 29**

Helvetica 20 Seraph 11 15 20 28 40 56

Rondo 52

Extra Fonts Disc N04

Eric 14 16

Eric Italic 16

Eric Swash 16

Scotch 12 16 18 26

Scotch Italic 16 18 26

**Scotch Wide 16**

Traditional 10 13 16 20

**Traditional Bold 16**

Traditional Italic 10 16 20

Traditional Inline 20

Slenda 22 42 64

Square 10

Type 15

**Type Bold 15**

**Wide 15**

Cuckoo 12 14 18 38 56

The Extra Fonts discs cost £14.95 each including VAT and postage.

This page is a one-to-one reproduction of a ProSCAN printout on a Canon Bubblejet printer

Please Supply ...

TICK

ProSCAN @ £179.95

Contact CT for details of Fax option and price without scan head

Extra Fonts Discs @ £14.95

No 1

No 2

No 3

No 4

Graphic Libraries @ £19.95

Maps (Two-disc set)

Parish Magazine (Two-disc set)

MicroDesign2-PC (for PCs and compatibles) £69.95

Upgrade to PC for registered PCW users £49.95

**TOTAL** (All Prices Include VAT and P&P)

£
---

I Enclose A Cheque Payable to Creative Technology (MicroDesign) Ltd.

Card No. 

--	--	--	--	--	--	--	--	--	--	--	--	--	--	--	--	--	--	--	--

Expiry Date 

--	--	--	--

 /

Name	
Address	
PostCode	
Telephone	

Order Date 

--	--	--	--

 / /

Send To CREATIVE TECHNOLOGY 10 PARK ST UTTOXETER STAFFS ST14 7AG



MICRODESIGN2 - CATALOGUE OF SUPPLIED ICONS

SHADE123  
(TRIPLE SET)

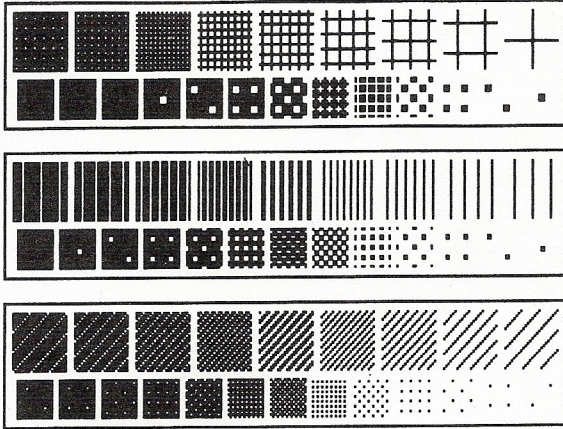

SHADEGEN

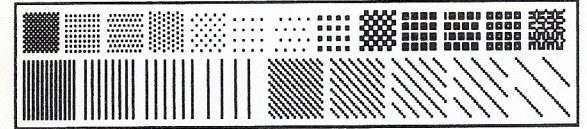

ARROWS  
(TRIPLE SET)

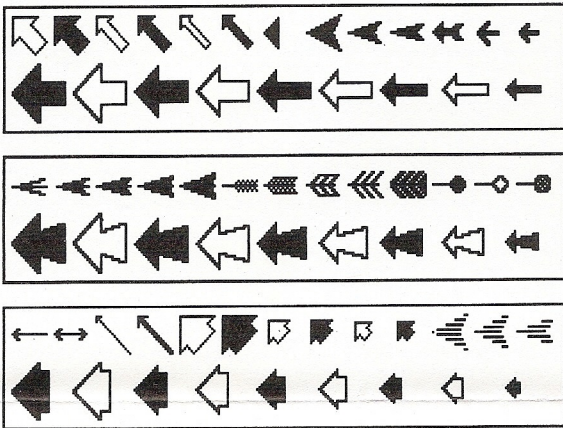

CORNERS

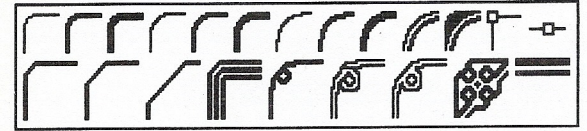

ELECGEN

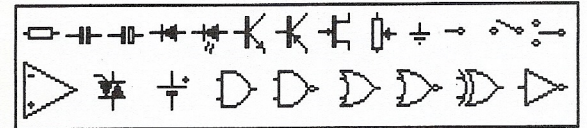

ELECTRON  
(TRIPLE SET)

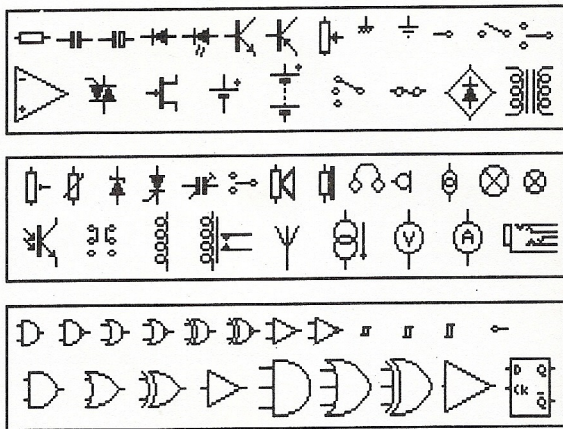

PATTERNI

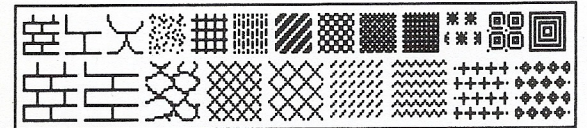

XMAS



FACES

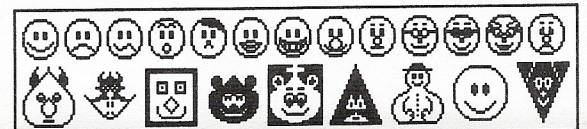

MISC1

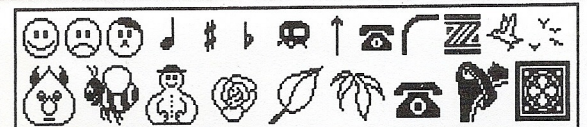

MISC2



TEXTURES

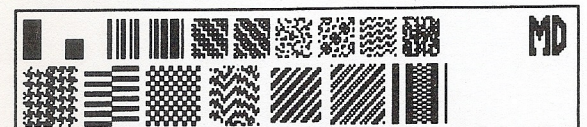

OSSYMBOLS

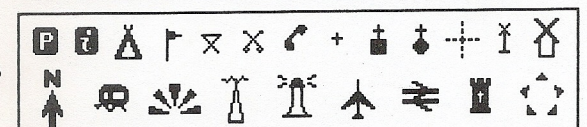

HYDRALIC  
(TRIPLE SET)

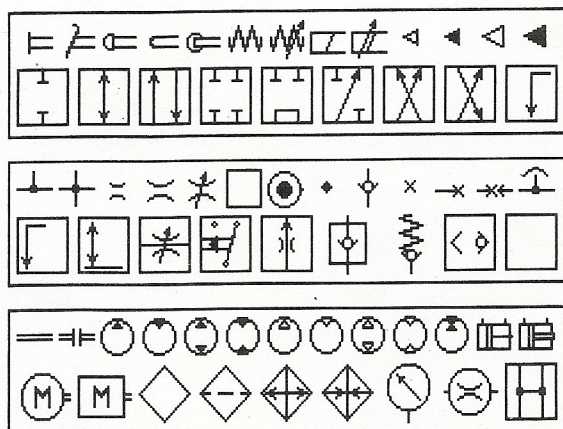

MUSIC

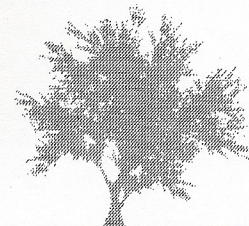
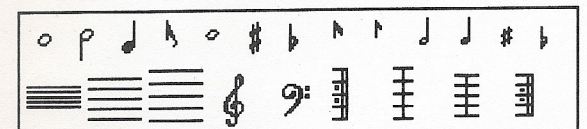

MICRODESIGN2 - CATALOGUE OF SUPPLIED FONTS

Filename (.MDF)	As printed at FULL scale			NOTES
	64k page	256k page	256k Strip	
ANGLIC16		ANGLIC 16	ABCDEF GHIJKLMNOPQRSTUVWXYZ abcdefghijklmnopqrstuvwxyz 0123456789 !"#\$%&*()-=+[]{}<>"'":;?/#%@	
BLOCK16		BLOCK16	ABCDEFGHIJKLMN O PQRSTU VWXYZ abcdefghijklmnopqrstuvwxyz 0123456789 !"#\$%&*()-=+[]{}<>"'":;?/#%@	Effective in 'Highlight' (White-on-Black)
BRDWAY16		BRDWAY16	ABCDEFGHIJKLMN O PQRSTU VWXYZ abcdefghijklmnopqrstuvwxyz 0123456789 !"#\$%&*()-=+[]{}<>"'":;?/#%@	
CIRCUL17		CIRCUL17	ABCDEFGHIJKLMN O PQRSTU VWXYZ abcdefghijklmnopqrstuvwxyz 0123456789 !"#\$%&*()-=+[]{}<>"'":;?/#%@	
CONDEN13		CONDEN13	ABCDEFGHIJKLMN O PQRSTU VWXYZ abcdefghijklmnopqrstuvwxyz 0123456789 !"#\$%&*()-=+[]{}<>"'":;?/#%@	
GRAMMA12		GRAMMA12	ABCDEFGHIJKLMN O PQRSTU VWXYZ abcdefghijklmnopqrstuvwxyz 0123456789 !"#\$%&*()-=+[]{}<>"'":;?/#%@	
HELVET08		HELVET08	ABCDEFGHIJKLMN O PQRSTU VWXYZ abcdefghijklmnopqrstuvwxyz 0123456789 !"#\$%&*()-=+[]{}<>"'":;?/#%@	Body Text for 64K Page Formats
HELVET12		HELVET12	ABCDEFGHIJKLMN O PQRSTU VWXYZ abcdefghijklmnopqrstuvwxyz 0123456789 !"#\$%&*()-=+[]{}<>"'":;?/#%@	
HELVET15		HELVET15	ABCDEFGHIJKLMN O PQRSTU VWXYZ abcdefghijklmnopqrstuvwxyz 0123456789 !"#\$%&*()-=+[]{}<>"'":;?/#%@	Used for the MicroDesign manual
HELVET23		HELVET23	ABCDEFGHIJKLMN O PQRSTU VWXYZ abcdefghijklmnopqrstuvwxyz 0123456789 !"#\$%&*()-=+[]{}<>"'":;?/#%@	
HELVLT15		HELVLT15	ABCDEFGHIJKLMN O PQRSTU VWXYZ abcdefghijklmnopqrstuvwxyz 0123456789 !"#\$%&*()-=+[]{}<>"'":;?/#%@	
HELVLT23		HELVLT23	ABCDEFGHIJKLMN O PQRSTU VWXYZ abcdefghijklmnopqrstuvwxyz 0123456789 !"#\$%&*()-=+[]{}<>"'":;?/#%@	
MODRN22		MODRN22	ABCDEFGHIJKLMN O PQRSTU VWXYZ abcdefghijklmnopqrstuvwxyz 0123456789 !"#\$%&*()-=+[]{}<>"'":;?/#%@	
OLDENG15		OLDENG15	ABCDEFGHIJKLMN O PQRSTU VWXYZ abcdefghijklmnopqrstuvwxyz 0123456789 !"#\$%&*()-=+[]{}<>"'":;?/#%@	
OLDENG23		OLDENG23	ABCDEFGHIJKLMN O PQRSTU VWXYZ abcdefghijklmnopqrstuvwxyz 0123456789 !"#\$%&*()-=+[]{}<>"'":;?/#%@	
SCRIPT27		Script27	ABCDEFGHIJKLMN O PQRSTU VWXYZ abcdefghijklmnopqrstuvwxyz 0123456789 !"#\$%&*()-=+[]{}<>"'":;?/#%@	Use Horizontal Spacing=0 Avoid continuous capitals
SANSERF9		SANSERF9	ABCDEFGHIJKLMN O PQRSTU VWXYZ abcdefghijklmnopqrstuvwxyz 0123456789 !"#\$%&*()-=+[]{}<>"'":;?/#%@	
SQUARE14		SQUARE14	ABCDEFGHIJKLMN O PQRSTU VWXYZ abcdefghijklmnopqrstuvwxyz 0123456789 !"#\$%&*()-=+[]{}<>"'":;?/#%@	
TIMES12		TIMES12	ABCDEFGHIJKLMN O PQRSTU VWXYZ abcdefghijklmnopqrstuvwxyz 0123456789 !"#\$%&*()-=+[]{}<>"'":;?/#%@	
TIMES14		TIMES14	ABCDEFGHIJKLMN O PQRSTU VWXYZ abcdefghijklmnopqrstuvwxyz 0123456789 !"#\$%&*()-=+[]{}<>"'":;?/#%@	
TIMES16		TIMES16	ABCDEFGHIJKLMN O PQRSTU VWXYZ abcdefghijklmnopqrstuvwxyz 0123456789 !"#\$%&*()-=+[]{}<>"'":;?/#%@	Good in Double-Strike
TIMES25		TIMES25	ABCDEFGHIJKLMN O PQRSTU VWXYZ abcdefghijklmnopqrstuvwxyz 0123456789 !"#\$%&*()-=+[]{}<>"'":;?/#%@	
TINY06		TINY06	ABCDEFGHIJKLMN O PQRSTU VWXYZ abcdefghijklmnopqrstuvwxyz 0123456789 !"#\$%&*()-=+[]{}<>"'":;?/#%@	
TINYCON6		TINYCON6	ABCDEFGHIJKLMN O PQRSTU VWXYZ abcdefghijklmnopqrstuvwxyz 0123456789 !"#\$%&*()-=+[]{}<>"'":;?/#%@	Good for labelling on 64K Page Formats
TYPWRT27		TYPWRT27	ABCDEFGHIJKLMN O PQRSTU VWXYZ abcdefghijklmnopqrstuvwxyz 0123456789 !"#\$%&*()-=+[]{}<>"'":;?/#%@	

**LAYOUT**  
 MENU...EXIT  
 DESIGN...D  
 Block..UNIT  
 SetWindow.W  
 Typeset...T  
 Box.....B  
 ClearPage.C  
 New.....N  
 Print....P  
 SaveTMPL.f8  
 LoadTMPL.f7  
 LoadFONT.f3  
 SaveAREA.f2  
 LoadAREA.f1

**TEXT EDITOR**  
 MENU...EXIT  
 Mark..Alt[  
 Bound.Alt[  
 Cut....CUT  
 Copy...COPY  
 Move..PASTE  
 Relay.RELAY  
 ClrText.CAN  
 SaveASCII.f8  
 SaveText.f6  
 LoadText.f5  
 MergeTxt.f3

**DESIGN**  
 MENU...EXIT  
 ZOOM.....Z  
 Block..UNIT  
 Stored..1-4  
 Write....W  
 Shape....S  
 Line.....L  
 Icon.....I  
 Paint....P  
 Flood....F  
 LoadICs.f5  
 LoadFONT.f3  
 SaveCUT..f2  
 LoadCUT..f1

**MAIN MENU**  
 LAYOUT...L  
 EDITOR...E  
 DESIGN...D  
 ICONS...I  
 FONTS...F  
 OPTIONS...O  
 QUIT.....Q

**ICONS**  
 MENU...EXIT  
 Edit.....E  
 Keep.....K  
 Clear....C  
 Nudge....N  
 Reflect..X  
 Reflect..Y  
 Invert...I  
 Rotate...R  
 Size.....S  
 SaveICs..f6  
 LoadICs..f5

**FONTS**  
 MENU...EXIT  
 Edit.....E  
 Keep.....K  
 Clear....C  
 Nudge....N  
 Reflect..X  
 Reflect..Y  
 Grab.....G  
 View.....V  
 SaveFONT.f4  
 LoadFONT.f3

**OPTIONS**  
 MENU...EXIT  
 SaveOPTS..S

**BLOCK OPS**  
 MARK then  
 Erase....f7  
 Invert...f5  
 Copy....f3

**TYPESET**  
 Exit...EXIT  
 Scaling..f7  
 Spacing..f5  
 Format...f3  
 MarkText.f1  
 ClrWndw.CUT  
 GO....PASTE

**ZOOM**  
 Exit...EXIT  
 Refresh...R  
 Clear....C

**BLOCK OPS**  
 MARK then  
 Erase....f7  
 Invert...f5  
 Copy....f3  
 Rescale..f1  
 Store...1-4

**WRITE**  
 Exit...EXIT  
 Scaling..f7  
 Spacing..f5

No of Columns: 1 2 3 4 5 6 7 8  
 Dividers : OFF ON  
 Column Margin: 0 1 2 3 4 5 6 7 8 9  
 Column Gutter: 0 1 2 3 4 5 6 7 8 9

Character Height: 23 ← X → 15 pt  
 Character Width : 22 ← X →  
 Character Gap : 2 ← Y →  
 Size Lock : OFF ON

Line Pitch : 24 ← X → 16 pt  
 Pitch Lock : OFF ON  
 Ruled Lines : OFF ON  
 Char Spacing : NON-PROP PROPORTNL

Line Format : LEFT-ALIGN RIGHT-ALIGN CENTRED **RT-JUSTIFY**  
 Justify : **CHARACTERS** WORDS  
 Auto-flow : OFF PAUSE AUTO-SKIP  
 TAB Spaces : 1 2 3 4 **5** 6 7 8 9 10 11 12 13 14 15

Select Page Format - 64k 256k  
 1: A4 Upright 4: A4 Upright  
 2: A4 Sideways 5: A4 Sideways  
 3: Strip 6: Strip

Print : **PAGE** QUEUE TEXT Copies : 1 2 3 4 5 6 7 8 9 X  
 Scale : **FULL** HALF QUARTER Paper : **CONT** SINGLE  
 Style : **DRAFT** QUALITY FmFeed : OFF ON  
 Margin : ← → Length : **CONTENT** PAGE

MICRO *design* 2  
**QUICK REFERENCE SHEET 2**

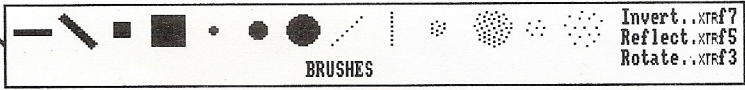

**ALL LOAD & SAVE OPERATIONS**

Drive B: User 00	LOAD AREA -- B:* .CUT	Free Space 68k	Drive.alt-v
BRSHMENU	FORMENU	NEAMENU	User..alt-u
DBLKMENU	ICONMENU	SHAPMENU	Rename...f7
DSGNMENU	LAYTMENU	OPTMENU	Erase...f5
EDITMENU	LBLKMENU	PRNTMENU	Directry.f3
FONTMENU	MAINMENU	SCALMENU	Areatype.f1
		WRITMENU	

Select filetype for Load Area  
 1:MicroDesign(.MDA) 4:Stop Press (.PAG) 7:Mini-Office(\* )  
 2:MDesign PC (.MDR) 5:CUT file (.CUT) 8:Runbo Vidi (.UID)  
 3:DesktopPubl(.GRF) 6:SCREEN type(\* ) 9:FSE Plus (.G )

**CURSOR**  
 Fast Cursor : 10 ← Y →  
 Cursor Blink : OFF ON

**MOUSE**  
 Mouse : OFF KEMPSTON AMX  
 Mouse Mouv : SLOW MEDIUM FAST  
 Double Click: SLOW MEDIUM FAST

**PRINTER**  
 Interface : PCMatrix CENTRONIC SERIAL232 9512-PAR  
 Printer Type : 9-pin A 9-pin B 24-pin A 24-pin B LASER A LASER B

**TEXTFILES**  
 ASCII Files : PROTEXT WORDSTAR (MDesign & Loco2 Auto-Detected)

## QUICK REFERENCE SHEET 1

### MOUSE

Left Button	Select / Move cursor
Right Button	Change Ctrl points
Left Double-Click	Fix Operation
Right Double-Click	UNDO

FIXING and UNDOing with the LEFT BUTTON:

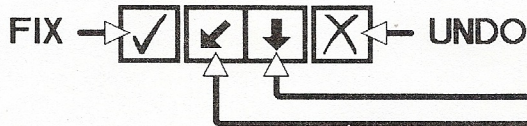

Note that these symbols are only displayed when their functions are actually available. This means, for example, that scrolling the screen in the Design Section removes the UNDO symbol, because the last Design operation cannot be UNDOed if the screen has been scrolled.

### KEYBOARD

#### Cursor Movement etc.

← ↑ → ↓	Cursor position control
with ALT	Fast movement
with SHIFT	Scroll (DESIGN) or Move Base/Margin markers (FONTS)
PAGE	Centre cursor on screen/Page
DOC	Centre screen on Page (DESIGN)
SPACE or FIND	Change control points
EXTRA+SPACE	Reduce frame size to zero

#### System Operation

LINE/EOL	DO (Select/Fix)
ENTER	Fix
WORD/CHAR	UNDO last Operation
STOP	Abort Current Operation
RELAY	Enter/Leave bottom window
SHIFT+ENTER	Scroll Map/Extra Menu (DESIGN only)
SHIFT+RELAY	Bottom window ON/OFF (DESIGN only)
EXTRA+R	Toggle Cursor Coordinates ON/OFF
ALT+STOP	Abort any Operation at any time

#### Text Editor

ALT+← →	Start / End of Line
ALT+↑ ↓	Top / Bottom of Screen
PAGE	Move Down 1 page
ALT+PAGE	Move Up 1 page
SHIFT+PAGE	End of File
SHIFT+ALT+PAGE	Top of File
EXTRA+⌘	Mark Typeset Start
EXTRA+⌘	Mark Typeset End

### The EXTRA FEATURES

While an operation is in progress, the bottom right corner of the screen displays the different features available in the operation. These features are called EXTRA FEATURES because they are accessed using the EXTRA key in conjunction with the fifteen keys at the right end of the PCW8512 keyboard, and they are represented by the following symbols:

	BLACK, WHITE or EXOR Inks for Point Plotting
	BLACK or WHITE Inks for Lines and Shape Outlines
	BLACK, WHITE or PATTERNED Inks for Flood, Filled Shapes, and Paint
	OPAQUE, TRANSPARENT or EXOR Ink Modes for Blocks and Filled Shapes
	MOVE or COPY for Block operations
	REFLECT X, Y, or X&Y for Block operations
	ROTATE through 90, 180 or 270 Degrees for Blocks
	Sizes of Points for Point Plotting
	LINE THICKNESS for Lines and Shape Outlines

	SOLID or DOTTED options for Lines and Shape Outlines
	STRAIGHT or ANGLED options for Lines
	Display the BRUSH or ICON Menus in Paint
<b>A S</b>	Save '.MDA' or SCREEN file in SaveArea
<b>B D H</b>	BOLD, DOUBLE-STRIKE or HIGHLIGHT text styles in Write and Typeset
<b>/ O U</b>	ITALIC, OUTLINE or UNDERLINE text styles in Write and Typeset
<b>INS OVR</b>	Select INSERT or OVERWRITE modes in the Text Editor Section
<b>WINDOW OFF ON</b>	Switch the WINDOW ON or OFF in Write

The example below shows the Extra Features used in the Shape operations, and the keys used to select them:

